



4651 Mercantile ave Naples, FL 34104

Phone Number: **Read Troubleshooting Section First!**

Email: info@gemremotes.com WWW.GEMREMOTES.COM

**Read All Directions Prior to Installation! Installation should be done
By a qualified technician and be wired to the NEC codes.**

Customer user instructions are printed on the yellow face card inside the GEM box make sure they are read before use! Use of other wiring directions could result in damage to your GEM unit and/or the motors.

We have 39 years of experience. We recommend that you read and use the Step by Step Wiring Procedures before starting the installation. It could save you time and money.

Step by Step Wiring Procedures:

To ensure proper installation of your GEM Controller, use our directions in lieu of all others.

Tools: Philip's #2 and a flat head screwdriver, wire strippers, volt meter and wire cutters and wire nuts.

1. **Turn off power at the circuit breaker. Check with a volt meter before wiring that you have 0 volts.**

Overload protection is not provided inside the GEM unit. Use properly sized circuit breaker and wire size based on horsepower of motors. See the wire chart on next page.

2. Do not remove the yellow face card screws, only open the junction(J) box below the GEM box.

3. Cut off drum (hand) switches, GEM units are not designed to be used in conjunction with switches. Strip main feed and motor wires inside the J box. **GR4** units are wired for 220/240VAC(2 wires + ground) Main feed black goes to GEM black the other main feed goes to GEM Red. **Only hook up main feed wires to GEM supplied wires. It is unsafe to use a ground as a neutral.** Use type 3 conduit hubs only.

4. Connect Motor #1-4 wires to GEM wires inside the J box. If an Auto-Run unit Motor 1 must be on the same motor as the limit switch. **(Do not hook up color to color inside the motor!)** Connect green or bare wires to GEM green these wires must only be used as a ground. Please use the chart on the next page for proper wire size. If you use the wrong size wire you could damage your motors, lift and/or the GEM unit. If you hear a grinding sound in the contactors during use then you have a voltage drop greater than 5%.

Caution: Bonding(grounding) between conduits(use type three only) is not automatic, it must be provided upon installation. **White motor wires are not used at 220/240!**

5. Open motor covers and configure motor wires as shown on the last page. If your motor has terminals inside, check for that motor diagram otherwise use the **Standard T Numbered Wired motor drawing** or the **Standard color motor-wired drawing**. **Inspect wires inside each motor to ensure proper wire connections. Failure to do so could damage your motors. You might have to move wires inside the motors even though the hand switches worked(AO Smith motors! Regal Beloit).** To reverse motor starting direction, swap wires **inside the motor!** Some motors have circuit protection and output wires from these might have different color wires. Also, some manufacturers pre-wire their motors with wires that don't match GEM wires. Some substitutions are blue for a green(ground), and yellow for a white wire. All motors must be configured for 220/240VAC.

6. If part number on the left side of the door has an "A" then your unit is an Auto-Stop(Run) mode. Your unit will not work without the limit switch wires hooked up. **Check that your lift stops in both the up and the down direction! An Auto-Stop unit must have GEM limit switch. Failure to do so could result in damage to your lift and/or the boat and is against code and not insured.** If the Auto-Stop LED is lit then the unit is in Auto-Stop mode, if it is flashing fast the lift is at an up limit and if slow then the lift is at the down limit. Press Auto-Stop(run) button to turn on/off the Auto mode. **The motor with the limit switch must be on if the lift is moving or lift will not stop.** 10. To level the lift, turn off the Auto-Stop mode(if equipped). Turn off all motors and adjust each side by turning one on at a time, raise or lower each one till level. **Do not turn off or on any motors while the lift is moving. The limit switch should be on motor 1!**

11. **Turn off the unit when not in use. Make sure the owner reads operating instructions printed on the yellow face card.** The emergency override holes bypasses the GFI(old gem inside box) protection, and if the GFI is buzzing stop or the GFI will be damaged! GEM units have a three second delay before switching directions. This ensures that all the motors turn on in the right direction.

12. A replacement transmitter (#7240) or a spare can be bought online at www.gemremotes.com. Loss of range or unit hiccups check battery, 2: 3 volts (Cr2032). Old, **6230 two button transmitters** will not work with this unit.

Use this chart to size wire and circuit protection. Measure the distance between the main breaker and the motors.

Recommended Wire Size for Installation of your GEM Controller-1 Phase, 75C Copper Wire

# of Motors	Motor HP	220/240 Volt AC Main Feed						
		Amps to run	Breaker Size	50 Feet	100 Feet	200 Feet	300 Feet	400 Feet
4	1/2	17.6	20	12	10	8	6	4
4	3/4	21.3	25	12	10	6	4	4
4	1	26.0	30	12	8	6	4	3
4	1 1/2	35	35	10	6	4	3	1
4	2	44.8	45	8	6	3	2	1/0

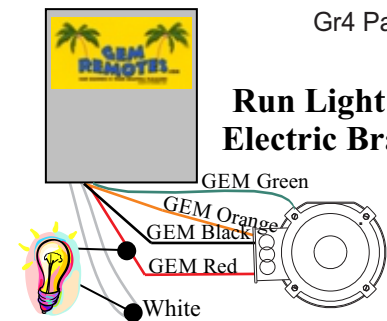

Attach the run light to the GEM Red & a neutral (120) even though the motor is wired for 220/240VAC .
If 220/240VAC brake is used, use GEM Orange and GEM Black. If you only have a 120VAC brake then you must have a neutral at the motor(120vac) and use neutral and the GEM motor red.

Breakers size is our recommendation. Please use motor label for proper size and code compliance. To protect the motors use the smallest size as possible even under sizing is recommend.

TROUBLESHOOTING:

- Your remote works but the face card membrane switch buttons don't. You need to plug in the M/S tail to the receiver board.
- You must **cut off drum switches**: They worked, but the GEM unit only works in one direction. You need to rewire inside motors, Note GEM Org wire might be to motor black this is not right.
- 1 or two motors turn in the wrong direction**: Switch motor wires, wires inside the motor, check motor name plate for reversing directions.
- Chatter or grumble in the contactor**: Turn off all the motors see that the contactor pull in for up and down. Turn on 2 motors at a time to see if they work. Turn on all switches check for low voltage, when system is running (override by pushing in contactor). Check wire size vs. run length all the way from the motors to the main breaker at the house. Example: 4 - 1hp motor wired at 240VAC 200 feet would need #6 wire to the GEM unit. The motor wire size should be ~1/4 the main feed size #10.
- Motor not working**: You must use GEM's motor wire diagrams. **Regal Beloit (A.O. Smith) motors move GEM Orange wire to pin 2!!** GEM units works with 120/240VAC 1 phase, cap. start, **induction run motors**. Three phase motors require a special unit please call. 1½ horsepower motors and larger can have a capacitor start and a cap. run. The run cap. might not reverse or the run cap. can explode. It may need to be removed. This will increase the run amps that the motor will draw by three amps. Eastbay motors, 2 cap systems require no modifications.
- Transmitter **does not work** a 3-second delay when switching direction. Check that LED on transmitter lights and check that the learn button LED lights when receiving from the transmitter. Relearn the transmitter, press the learn button 1 time and then push the Stop button the Learn LED should flash.
- Short range or lift hiccups**: If the red LED on the transmitter **flickers, replace the batteries 2: 3Volt CR2032**. Do not change the length of the antenna wire this will not help the range. You should have line of sight for the unit to have up to 300-foot range.
- If the lift does not move, make sure all 4 motor switches are on. If the GEM unit is dead check that the LEDs at the top flashes when turned on. If no flash then check your power you can also press in the middle of bottom contactor if the lift runs, you have main power but your 24 VAC transformer is not working. **Auto-Stop units must be hooked up to a limit switch**. A fast flash on the LEDs means that the up limit is reached a slow flash is for the down limit. If the led are flashing fast then slow then both limits are open check to see if it hooked up or wire damage. **It is against code and not covered by insurance to be used without a GEM limit switch. Motor #1 should have the limit switch attached at that motor.**
- Clearing the memory**: Press and hold the Learn/Clear button for seven seconds (LED will light) when the LED flashes stop pressing and memory will be cleared. Test to see if it works. To learn, press the learn/clear button once, then press the Stop button on the transmitter. The Learn LED will flash 2 times.
- TROUBLESHOOTING: Old GEM GFI units** need a neutral. **GFI will not reset if it sees a fault or it does not have 120VAC**. Turn off all 4 motor switches, check to see if the GFI resets: press up and down. See if the contactor is pulling in, then turn on 1 motor at a time to find the fault. Test in both up and down direction. **GEM GFI units need 3 wires + ground. If you do not have 3 + G then you will need to remove the GFI and replace with a Decora on/off switch and rewire the transformer. You will not have GFI protection and we recommend that you add a GFI breaker.**
- TROUBLESHOOTING: Wiring at 220VAC-240VAC 50 to 60hz**: 4 motor or special ordered **240V only units** do not have a white wire unless it is an old GEM GFI unit. Read the label, on top of the transformer BLK-Red = 240 VAC. **Cap off white wire**. Find the Red transformer wire, it should be hiding between the 2 contactors on the left it has a brown wire taped to it. Attach the Red transformer wire to L2. The brown wire taped to this wire is used for 208 vac connections don't use.
- TROUBLESHOOTING: Wiring at 208VAC**: Rewire the transformer. Read the label on the transformer BLK-Brown=208 Remove white wire from neutral bar and tape it off. Find Brown transformer wire, it should be hiding between the 2 contactors on the left, it is taped to an Red wire. Attach Brown transformer wire to L2. The RED wire that it was taped to is for 240 connections. Old GFI inside the gem units need a 120vac to work.

Need more help? Call 239-642-0873 M-F 900-4:30 EST. See WWW.GEMREMOTES.COM for more information.

90 % of motors are the 2 top left diagrams. If your motor has terminals then use that specific drawing below. Otherwise, use the standard T# or colored wire drawings.

Standard "T#" or # Wires
Wires Wired at 240 VAC.
AO Smith, Baldor, Dayton, Deco
Electorgear, Emerson, GE, Iron
Horse, Leeson, Lincon, Marathon,
WEG, SMC and other "T#"

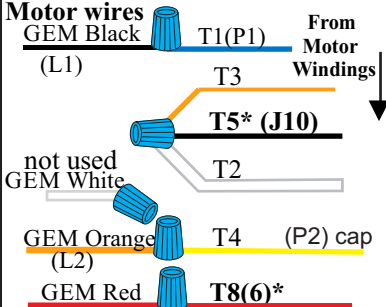

Motor wires
GEM Black (L1) **T1(P1)** From Motor Windings
GEM Orange (L2) **T4 (P2) cap**
GEM Red **T8(6)***
 *To change motor direction, switch T5 & T8 motor wires inside the motor!!!!
To change from 120 to 240VAC:
 1. Cap GEM White wire (not used)
 2. Attach 3 motor wires together T3, T5* and T2.
 3. FYI: GEM Blk to T1(P1), GEM Org to T4, GEM Red to T8(6)*. **wire inside the motor!!!!**

Standard Colored Motor
Wired at 240 VAC.
A.O. Smith, Baldor, Dayton,
Electorgear, Emerson, Elite, Iron
horse, Leeson, Lincon, Marathon
& other Colored Motor

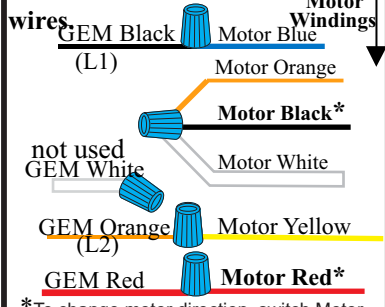

Wires
GEM Black (L1) **Motor Blue** From Motor Windings
GEM Orange (L2) **Motor Yellow**
GEM Red **Motor Red***
 *To change motor direction, switch Motor Red and Motor Black wires inside the motor!
To change from 120 to 240VAC:
 1. Cap GEM White wire (not used)
 2. Attach 3 motor wires' together M Org, M Blk* and M White.
 3. FYI: GEM Black to Motor Blue, GEM Orange to Motor Yellow, GEM Red to Motor Red*.

Regal Beloit AO SMITH
Wired at 240VAC.
 Note: Drum switch Org might be pre-wired to Motor Black*. GEM Orange needs to be on pin 2. Also move Motor White and Motor Black wires to pin 4 and 3.

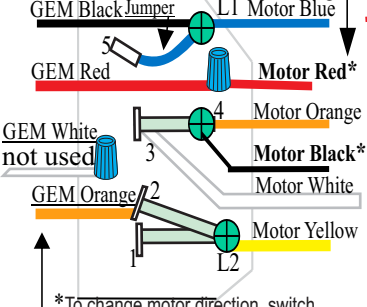

*To change motor direction, switch Motor Black & Motor Red wires.
Wiring From GEM Unit
To change from 120 to 240VAC:
 1. Cap GEM White wire (not used).
 2. Place Motor Black on pin 4.
 3. Move Motor Blue jumper from pin 4 to pin 5.
 4. **GEM Orange is on pin 2!!!!!!**
 5. Move Motor White from pin 1 to 3

Elite Wired @ 240 VAC

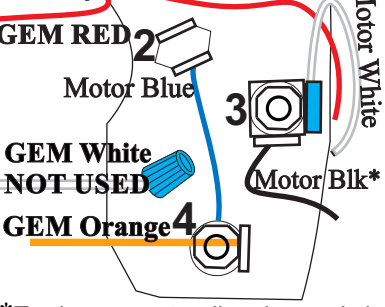

*To change motor direction, switch Motor Black & Motor Red wires.
To change from 120 to 240VAC:
 1. **Place Motor Black on pin 3!!!!!!**
 2. Move Motor White from pin 1 to 3
 3. Cap GEM White wire(not used)
 4. Move Motor Blue jumper from pin 3 to pin 2.

Century/MagneTek
Wired @ 240 VAC

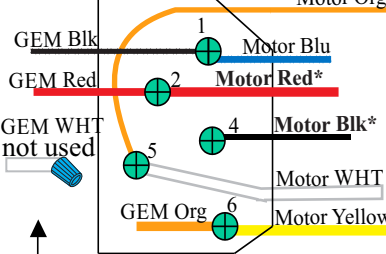

Wiring From GEM Unit
 *To change motor direction, switch Motor Black & Motor Red wires.
To change from 120vac to 240:
 1. Cap GEM White wire (not used).
 2. Move Motor Orange from pin 1 to pin 5.
 3. Move Motor White from 6 to pin 5.
 4. FYI: GEM Black and Motor Blue on 1, GEM Orange and Motor Yellow on 6.

Wired @240 VAC
C412, C426 AND C523
Century AC/A.O. SMITH

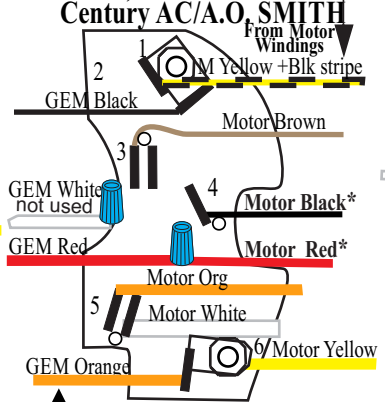

Wiring From GEM Unit
 *To change motor direction, switch Motor Black! & Motor Red wires!
To change from 120vac to 240:
 1. Cap GEM White wire (not used).
 2. Motor black on 4.
 3. Move Motor Org from 3 to 5.
 4. Attach M Whit & M Org on pin 5.
 4. FYI: GEM Org & M Yellow on 6.

EMERSON
Wired at 240VAC

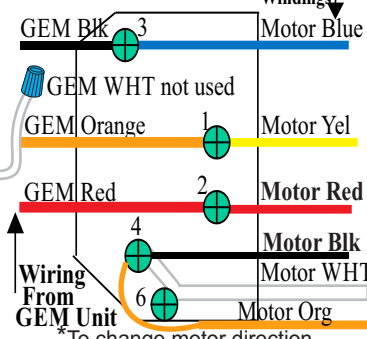

Wiring From GEM Unit
 To change motor direction, switch Motor Blk and Motor Red* wires.
To change from 120vac to 240:
 1. Cap GEM White wire. (Not used)
 2. Attach (3) motor wires on #4 M WHT, M Blk* & M Org.
 3. FYI: Gem Blk & Motor Blue on 3 GEM Org & Motor Yellow on 1 GEM Red & Motor Red* on 2.

BALDOR
(BALDOR "T" NUMBERED WIRES
SEE NUMBERED WIRE DRAWING)
Wired at 240VAC

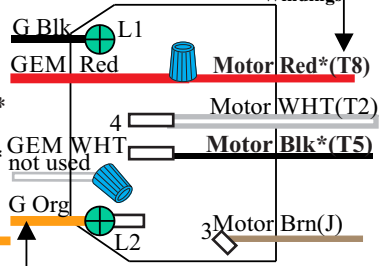

Wiring From GEM Unit
 *To change motor direction, switch M Blk(T5) & Motor Red(T8) wires.
To change from 120 to 240VAC:
 1. Cap GEM White wire (not used).
 2. Place M Black*(T5) on pin 4.
 3. Move M Brn(J) from pin 4 to pin 3.
 4. Move M WHT(T2) from L2 to pin 4.

LEESON/Ace
Wired at 240 VAC

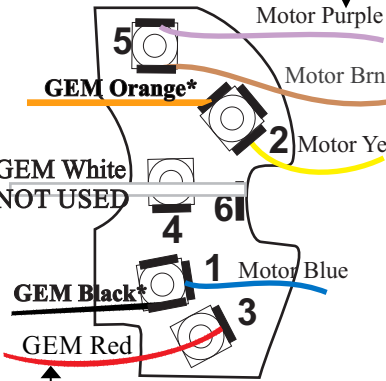

Wiring From GEM Unit
 *To change motor direction switch GEM Org & GEM Blk wires
To change from 120vac to 240:
 1. Move GEM White from pin 5 to 6.
 2. Move motor Purple wire from 1 to 5.
 3. Move motor Brown wire from 2 to 5.
 4. **To change direction of the motor switch GEM Org & GEM Black wires.

Marathon/GE
Wired @ 240 VAC

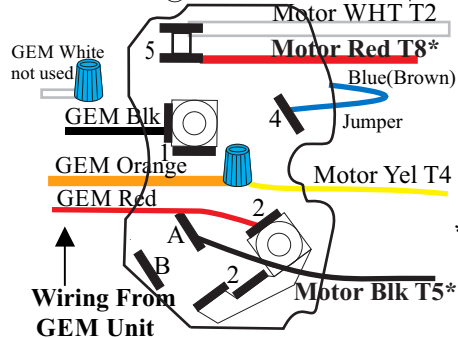

Wiring From GEM Unit
To change from 120vac to 240:
 1. Cap GEM White wire (not used).
 2. Move Blue Jumper from 5 to 4.
 3. Attach M WHT & M Red*(T8) on pin 5.
 4. FYI: GEM Org & M Yellow together.

*To change direction, switch Motor Black T5. & Motor Red T8 wires.

For EastBay Motor wiring Instructions goto GEMRemotes.com wire diagram 2000-2008